

TP 1669-1613 10 LT (4) Dimensions

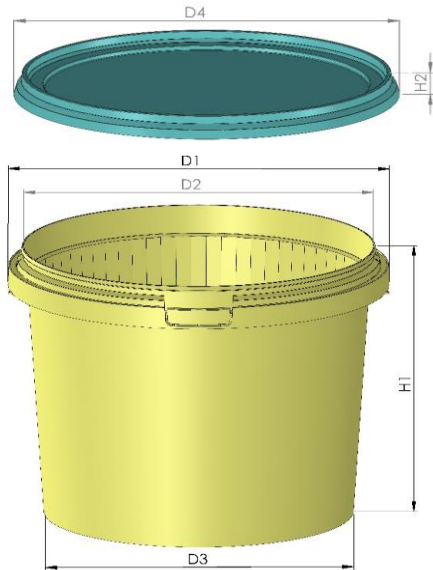

Shape :	Round Conical
D-1	275,5 mm +/- %1
D-2	263,1 mm +/- %1
D-3	235,3 mm +/- %1
D-4	273,1 mm +/- %1
H-1	235 mm +/- %1
H-2	10,5 mm +/- %1

Volume

Brimful Volume :	11010 cc
Iso Volume :	10300 cc

Weight

Weight container / pot	235 gr. +/- 5 gr.	Weight standard handle	9,5 gr. +/- 0,5 gr.
Weight standard lid	67,5 gr. +/- 3 gr.		

Performance

Hot filling	85-95 ° C
Hot temperatures	The material chosen has a very good heat resistance and the pails are suitable for hot filling. Notably, plastic pails become flexible when subjected to hot filling temperatures and care must be taken in relation to stacking immediately after hot filling. The TP 1669-1613 must be tested by the customer with the actual product before approval for use at hot temperatures.

Handle

Available handle	TP 1560	Handle type	Flexible Plastic
------------------	---------	-------------	------------------

Closure System

Lid type options	Standard Lid
Closure type	Snap-On
Protective collar	Yes
Tamper Evidence Type	Tamper Evidence tap





Decoration

Decoration Available :	<input checked="" type="checkbox"/> Offset	Decoration area offset	180 mm x 760 mm
	<input type="checkbox"/> IML	Decoration area IML(Pail)	-
		Decoration area IML(Lid)	-

Packaging (Per both lid and pail)

	1100 X 1200
On pallet	896 pcs.
Pallet Height	250 cm.
Amount of pallets per 40"HC	20 pallet
Amount of pcs per 40" HC	17.920 pcs.
Amount of pallets per truck	24 pallet
Amount of pcs per truck	21.504 pcs.

Raw Material Quality Specifications

PP   ISO 9001 - 2008
ISO 22000 - 2005

